



Interchangeable Truck Body System

SALT SPREADER BODY



SWITCHNGO.COM



Features

- Superior Weight Distribution as compared to non-specialized upfits
- 4.8 Cubic Yard 304 Stainless Steel V-Box
- 12" Angled Front Extension
- 9" Rear Cutout for Conveyor
- Sloped Front Design
- Retractable Legs for interchangeability & storage without removing the chute
- 10,000lb maximum load operation
- Expanded metal subframe floor to prevent material buildup



FEATURES



9" Rear Cutout for Conveyor



12" Angled Front Extension

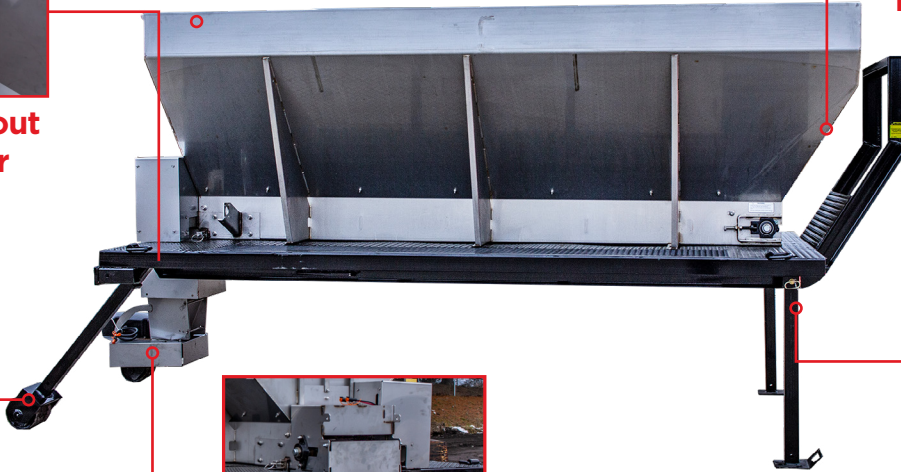

Detachable Ground Rollers



Electric Conveyor and Spinner



Retractable Legs

SPECIFICATIONS

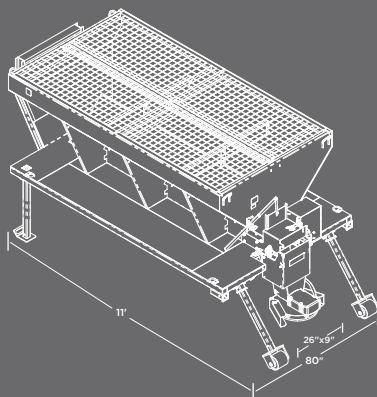

11' LENGTH ONLY

WORKING LOAD LIMIT	10,000LBS
SPREADER CAPACITY	4.8YD
ATTACHMENT POINTS	4 D-RINGS RATED AT 4080LBS
FLOOR	SIDE 19" WIDE EXPANDED METAL 3/4" CENTER 40" WIDE DIAMOND SHEET 1/8"
REAR CUTOUT	26" WIDE X 9" DEEP
LEGS	DETACH AND STOW
SPREADER CONVEYOR	ELECTRIC

Specifications are subject to change without notice. For warranty information on this or any other Switch-N-Go® product please refer switchngo.com/warranty.

1.800.263.1262 | jjei.com



**Joe Johnson
Equipment**
Subsidiary of Federal Signal Corporation