

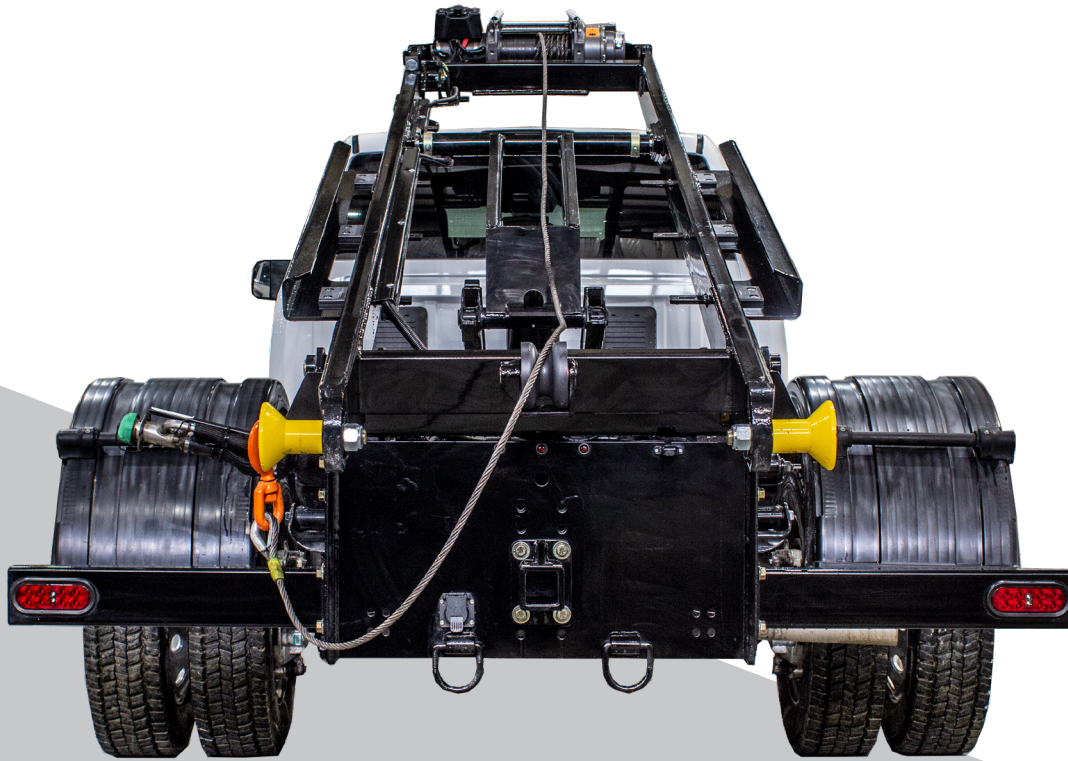

Interchangeable Truck Body System

# HOIST SYSTEM



### Body Hold Downs

Universal design to secure multiple body lengths\* with one system  
\*Bodies must be system length or shorter



### Hook Point

Integrated cable hook stowing on both sides of system



### Pendant Control

Simple design for single-handed operation



### Swivel Hook

Reduces cable stiffness for improved cable spooling and body attachment

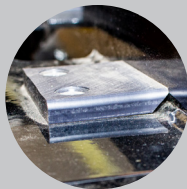

### Slide Pads

Provide low friction body support and reduced wear on the system/body rails

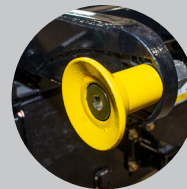

### Body Rollers

Single piece, self-greasing and bolt-on design for smooth rolling

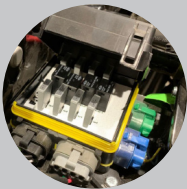

### Electronics System

Fully enclosed and waterproof junction box with an IP 66 rating



### V Roller

Poly material to reduce excessive wear and extends cable life



### Pump Cover

Provides additional protection to the pump

## Features

- Ideal for chassis cab vehicles with a GVWR of 13,500-33,000lbs
- Compatible with vehicles ranging from 60" CA to 138" CA
- Bolt on design allows for easy transfer between chassis
- Easy single handed operator controls with in-cab and on-hoist connection points
- Strong, lightweight system to maximize truck payload
- Variety of dump capacities up to 12.6 tons
- Hoist System can raise up to 50° dump angle
- Self-engaging front body Lock to secure body during transport and dumping



## E SERIES HOIST SYSTEM

**E Series** | Is an electric powered hydraulic hoist system built for medium duty workloads and is ideal for class 4-7 chassis cab vehicles with a GVWR of 13,500lbs-26,000lbs. The system is designed to handle six fully loaded winch draws per day.\*

15,000 lbs

IDEAL FOR  
M DUTY  
WORKLOADS

6  
LOADED  
LIFTS

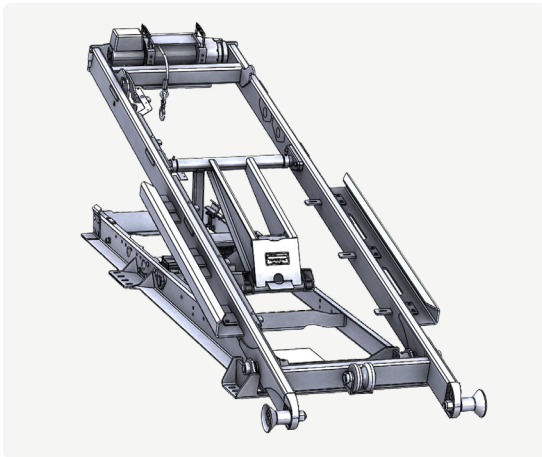

Model Name	Dumping Capacity (tons)	Minimum CEF (in.)	Winch Capacity (lbs)	Overhang Length (in.)	Typical CA (in.)
9-4016-15ES-11T	11.4	108" (9')	15,000	6"	60"
11-4016-15ES-9T	9.2	132" (11')	15,000	6"	84"-96"
11-4016-15E-10T	10.3	132" (11')	15,000	18"	84"-96"
11-4020-15E-12T	12.6	144" (12')	15,000	18"	84"-96"
12-4020-15E-11T	11.3	144" (12')	15,000	18"	96"-108"
14-4020-15E-9T	9.3	168" (14')	15,000	18"	120"-138"
14-5020-15E-10T	10.3	168" (14')	15,000	18"	120"-138"

\*A fully loaded winch draw is equal to the rating of the winch, which is 15,000lbs. If you are loading 15,000lbs (body and payload), the system can pull six loads per day. If you are loading a lesser weight, the system will be able to pull more than six loads per day. For example, if your load is 10,000lbs (body and payload), the system can pull approximately 10 loads per day.

\*Refer to your vehicle operator guide for manufacturer recommendations on GVWR

## H SERIES HOIST SYSTEM

**H Series** | Is a full hydraulic hoist system built for heavy duty workloads and is ideal for class 5-7 chassis cab vehicles with a GVWR of 16,001lbs-33,000lbs

UP TO  
18,000 lbs

IDEAL FOR  
H DUTY  
WORKLOADS

UNLIMITED  
LIFTS

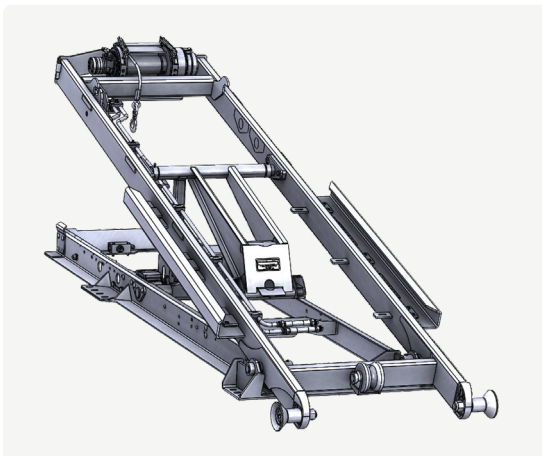

Model Name	Dumping Capacity (tons)	Minimum CEF (in.)	Winch Capacity (lbs)	Overhang Length (in.)	Typical CA (in.)
11-4016-15H-10T	10.3	132" (11')	15,000	18"	84"-96"
11-4020-18H-12T	12.6	144" (12')	18,000	18"	84"-96"
12-4020-18H-10T	11.3	144" (12')	18,000	18"	96"-108"
14-5020-15H-10T	10.3	168" (14')	15,000	18"	120"-138"
14-5020-18H-10T	10.3	168" (14')	18,000	18"	120"-138"

Specifications are subject to change without notice. The Gross Vehicle Weight (GVW) or Gross axle weight rating (GAWR) will limit the operating capacity of the vehicle upfitted with a hoist system. For Switch-N-Go® product warranty information, please refer [switchngo.com/warranty](http://switchngo.com/warranty).