



Interchangeable Truck Body System

FLATBED



Features

- High quality zinc prime & powder coated finish
- Lightweight design
- 24" on center stake pockets
- Lasercut window in bulkhead
- 4-Corner chain keyholes
- Low profile 4" steel ground rollers
- Custom options available

Distributor Info:

SWITCHNGO.COM



TRUCK BODY OPTIONS



Welded D-rings

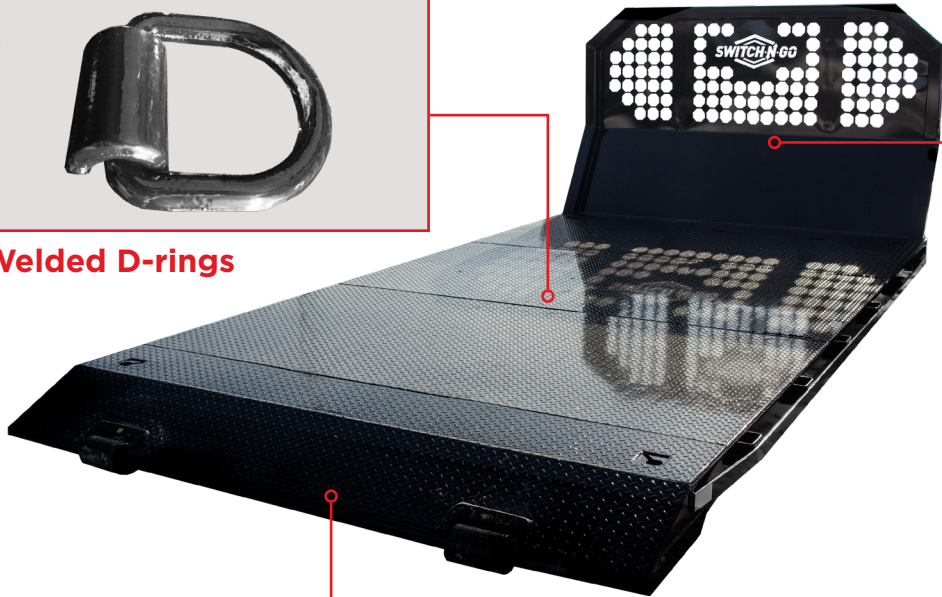

39" Height Bulkhead



51" Height Bulkhead



Optional No Beavertail w/
6" Ground Rollers

SPECIFICATIONS

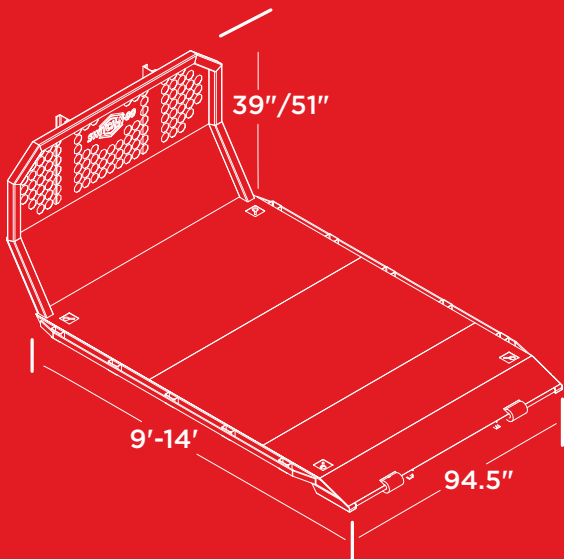

	9-12' LENGTHS	13-15' LENGTHS
FLOOR	1/8" DIAMOND PLATE	3/16" DIAMOND PLATE
OUTER RAIL	3" x 3" x 1/8" TUBING	
STAKE POCKETS	24" ON CENTER	
RUB RAIL	3/8" X 2" FLATBAR	
ROLLERS	INTEGRATED 4" X 6" WIDE GROUND ROLLERS	
CROSSMEMBERS	3" STRUCTURAL CHANNEL ON 16" CENTERS	
KEYHOLES	LOCATED IN CORNERS OF PLATFORM FLOOR	
	STANDARD BULKHEAD	HIGH BULKHEAD
BULKHEAD WINDOW	≈ 3.8 SQ FEET AREA	≈ 4.4 SQ FEET AREA

Specifications are subject to change without notice. For warranty information on this or any other Switch-N-Go® product please refer switchngo.com/warranty.

