

A5-OR-250 TRAILER HOIST



www.galbreathproducts.com



*EX model shown

The **A5-OR-250** trailer hoist is a heavy-duty hoist for use in the scrap industry. Designed to handle punishing loads, the 250 is engineered for durability and years of service.

- Available Models:**
- Deadlift (HH)
 - Extendable Tail (EX)
 - Inside/Outside Rail (IO)
 - Outside Rail (OR)



*EX model shown

Features

- ▶ Designed for hauling scrap and refuse
- ▶ 60,000 lb. manufacturer's rated capacity
- ▶ Handles 22-30' containers
- ▶ Proven Galbreath quality means the hoist is built to last
- ▶ Two outboard lift cylinders provide greater stability
- ▶ Available in OR, IO, EX and HH models
- ▶ Other trailers compatible for up to 39' containers in the A5 series
- ▶ Good return on investment
- ▶ High resell value

Options

- ▶ Lift axle
- ▶ Air ride suspension
- ▶ Tire carrier
- ▶ Wet kit
- ▶ Rear wing plate

All Galbreath products are designed to be compliant with ANSI standard container requirements.

A5-OR-250 TRAILER HOIST

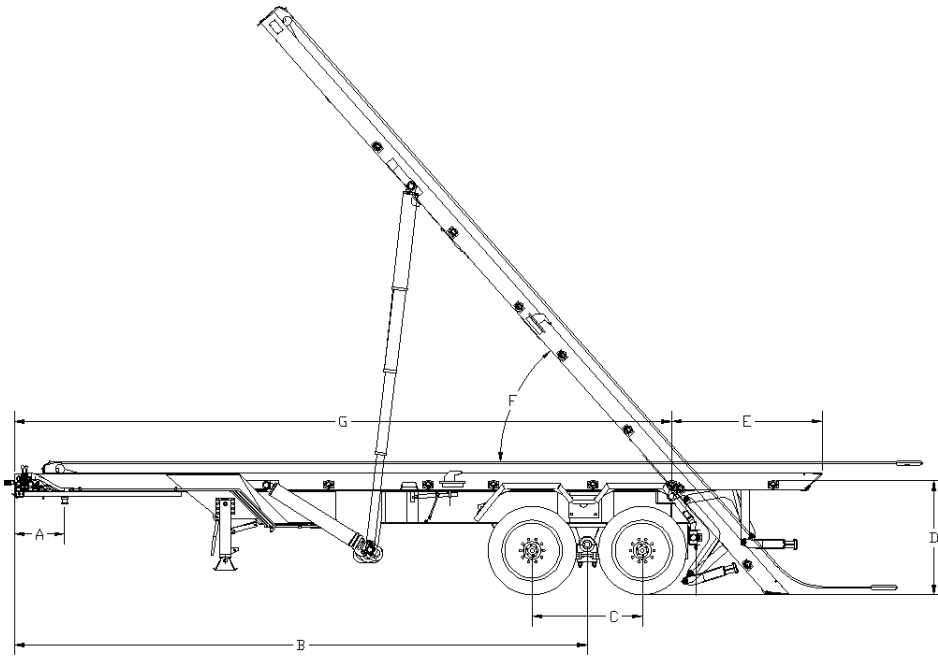

A = 18"
 B = 275 3/4"
 C = 53"
 D = 55 1/16"
 E = 72 5/8"
 F = 49°
 G = 316 1/4"

GENERAL TRAILER INFO

Overall Trailer Length	(G + E) = 32'5"
Weight	16,500 LBS
Dump Angle	(F) 49°
Ratchet / Hold Down System	Ratchet / stationary hold downs
Container Range	22' - 30' (22' - 26' for EX & HH Models)
Hoist Capacity	60,000 LBS (50,000 LBS HH Models)
GVWR Rating	60,000 LBS (50,000 LBS HH Models)
Rollers / Sheaves	ALL GREASABLE
Lighting	LED

STRUCTURES

Hoist Frame	8" X 4" X 1/2" Rect. Tubing ASTM A500 Grade C (3/8" EX)
Trailer Frame	16" X 36# W.F. I-Beam A36
Cable	7/8", 6 x 37 EXIWRC REGULAR RIGHT LAY
Finish / Paint	Two Part Epoxy Primer & Paint

AXLES, SUSPENSION AND BRAKING

Axles Rating	25,000 LBS
Suspension Rating	50,000 LBS Hutch Single Point Tandem
Landing Gear	200,000 LBS, 2 Speed
Tires	11R X 22.5 16 Ply
Wheels	10 Hole Hub Piloted
Fenders	Full Steel - 12 Gauge Front, 14 Gauge Rear
Brake System	ABS

HYDRAULICS

Lift Cylinders	6"-5"-4" X 118" DA TELESCOPIC
Winch Cylinders	4" DA, 3" GROUND, POLISHED & CHROME
Working Pressure	2,000 PSI
Maximum Pressure	2,500 PSI
Hoses	SAE 100R2 or Greater for 5,000 PSI Max, 2,500 PSI Working
Plumbing	Hydraulic Steel Tubing



**Joe Johnson
Equipment**

Subsidiary Of Federal Signal Corporation

1.800.263.1262 | jjei.com | info@jjei.com

Galbreath is a Wastequip brand. Wastequip is the leading North American manufacturer of waste and recycling equipment for collecting, processing and transporting recyclables and solid or liquid waste. © January 2015 Wastequip, all rights reserved. Specifications subject to improvement without notice. Equipment displayed should be operated by properly trained personnel. Operators should become familiar with OSHA, ANSI and any other applicable standards or laws for using this equipment. Improper use, misuse, or lack of maintenance could cause injury to people and/or property. Photos used in the literature are illustrative only. We assume no liability or responsibility for proper training/operation of equipment not manufactured by Wastequip. We reserve the right to make changes at any time without notice. Information contained within this literature is intended to be the most accurate available at time of printing.

GAL004-01201